

注: 本图只作基准使用, 复制、编辑时, 以及用其内容进行标注

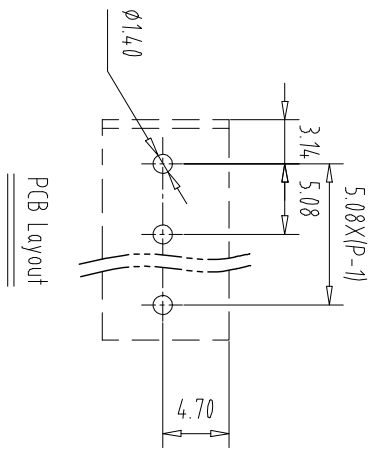
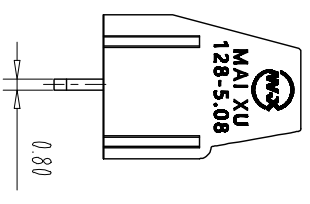
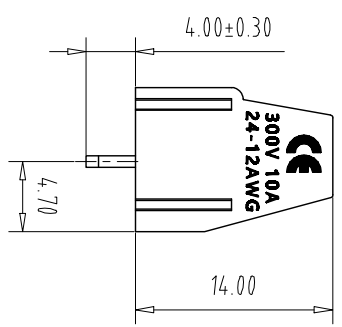
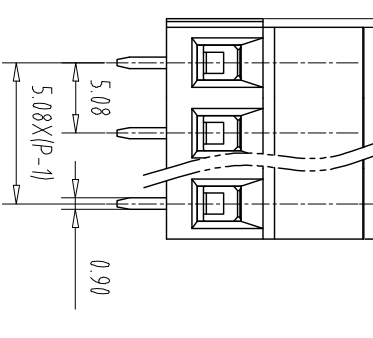
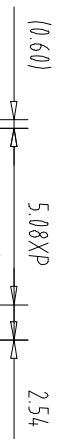
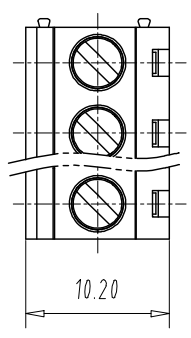

REV	ECN NO.	CONTENT	CHK	DATE

NOTES1:
UL Standard
1.Rating voltage/current: 300V//10A
2.withstanding voltage: AC2000V//1Min
3.Torque value: M2.5, 3.54Lbin
4.Wire range: 24~12AWG

IEC Standard

Pollution Degree	3	2	2
Overvoltage Category	III	III	II
Rate Impulse Voltage(KV)	4	4	4
Rate Voltage(V)	250V	400V	630V
Rate Current(A)	15A	15A	15A

2. Torque value: M2.5, 0.4Nm
3.wire range: 0.2-2.5mm²

NOTES2:
1.Housing: PA66(UL94V-0)
2.Solder Pin: Copper alloy(Sn Plated)
3.Cage: Steel(Zn Plated)
4.Screw: Steel(M2.5,Zn Plated)

NOTES3:
1.Pitch: 5.08mm Poles: 02-24P
2.Stripping length: 6-7mm
3.Operating temperature: -40℃~+105℃
4.RoHS Compliance

How to order
MX128 - 508 - XXX - XXXX - XX - X - X

产品型号 间距 颜色 极数

颜色: GY 灰色: OE 02-99: 01-常规颜色
蓝色: BU 红色: RD 定制颜色
黑色: BK 透明色: TT
绿色: GN 黄色: YW
白色: WE

A-Z其他定制
0-Y一字螺丝
1-S十字螺丝
Cu:铜方块
Fe:铁方块
2-PS平头十字螺丝

Pitch Range In mm	Nominal Dimension In mm	Range	Symbol					
Over 6 TO	Over 10 TO	Over 30 TO	Over 60 TO	Over 100 TO	Over 150 TO	Over 150 TO	0.1/10	
±0.15	±0.20	±0.30	±0.30	±0.50	±0.70	±1.00	±1.30	±2°

ITEM	NAME OF PART	NO. OF PART	Q'TY	MATERIAL	NOTE
DWG	CHK	DATE	UNITS	MM	SHEET/OF
APP	DATE	SCALE	1:1	A4	1/1
CIXI MAIXU ELECTRONICS CO.,LTD.					NAME
MAIXU 慈溪市迈旭电子有限公司					MX128-5.08-XXX
DWGNO.					