

注: 本资料禁止传输、复制、编辑、修改, 以及相关附件内容按此规范

REV	ECN NO.	CONTENT	CHK	DATE

NOTES:

UL Standard	1	2	3	4
Use group	B	C	D	
Rated Current	15A	/	10A	
Rated Voltage	300V	/	300V	

IEC Standard	1	2	3	4
Overvoltage Category	III	III	II	
Rate Impulse Voltage(KV)	/	/	4.0KV	/
Rate Voltage(V)	/	/	320V	/
Rate Current(A)	/	/	15A	/

- 1. Pollution Degree 3
- 2. Torque value: M2.5, 0.4Nm
- 3. Wire range: 0.2~2.5mm²
- 4. Housing: PA66 (UL94V-0)
- 5. Cover: PA66 (UL94V-0)
- 6. Cage: Brass (Ni Plated)
- 7. Conductor: Copper alloy (Sn Plated)
- 8. Screw: Steel (M2.5, Zn Plated)

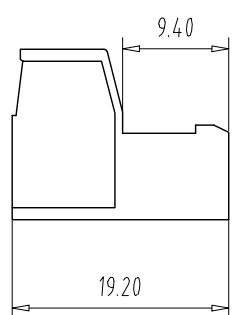
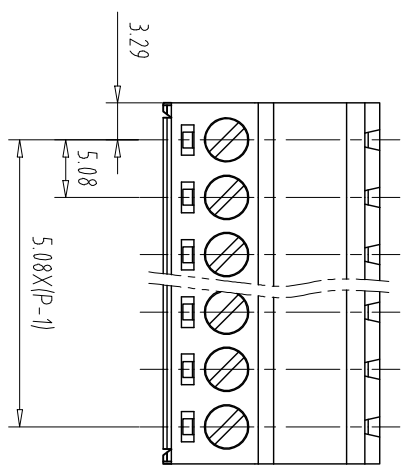
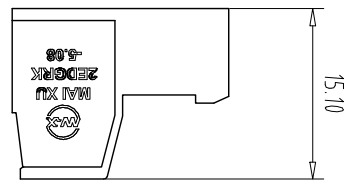
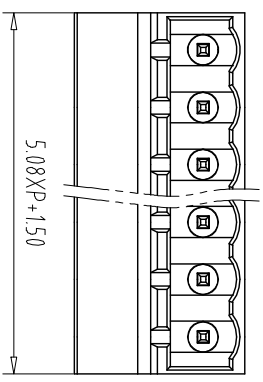

- NOTES:
1. Pitch: 5.08mm Poles: 02-24P
 2. Stripping length: 7-8mm
 3. Operating Temperature: -40℃~+105℃
 4. RoHS Compliance

How to order

MX2EDGRK - 508 - XXP - XXXX - XX - X - X

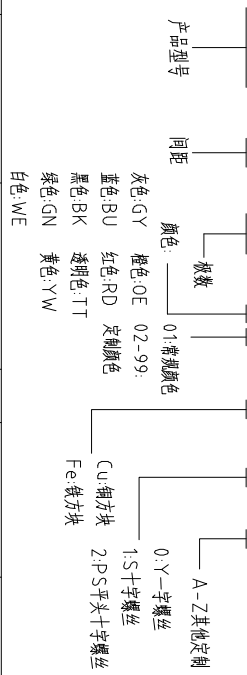

Pitch Range In mm	Nominal Dimension In mm	Range
Over 6 TO	Over 10 TO	Over 30 TO
Over 10 TO	Over 24 TO	Over 60 TO
Over 15 TO	Over 30 TO	Over 100 TO
Over 20 TO	Over 30 TO	Over 150 TO
Over 25 TO	Over 30 TO	Over 150 TO
Over 30 TO	Over 30 TO	Over 150 TO
Over 35 TO	Over 30 TO	Over 150 TO
Over 40 TO	Over 30 TO	Over 150 TO
Over 45 TO	Over 30 TO	Over 150 TO
Over 50 TO	Over 30 TO	Over 150 TO
Over 55 TO	Over 30 TO	Over 150 TO
Over 60 TO	Over 30 TO	Over 150 TO
Over 65 TO	Over 30 TO	Over 150 TO
Over 70 TO	Over 30 TO	Over 150 TO
Over 75 TO	Over 30 TO	Over 150 TO
Over 80 TO	Over 30 TO	Over 150 TO
Over 85 TO	Over 30 TO	Over 150 TO
Over 90 TO	Over 30 TO	Over 150 TO
Over 95 TO	Over 30 TO	Over 150 TO
Over 100 TO	Over 30 TO	Over 150 TO
Over 105 TO	Over 30 TO	Over 150 TO
Over 110 TO	Over 30 TO	Over 150 TO
Over 115 TO	Over 30 TO	Over 150 TO
Over 120 TO	Over 30 TO	Over 150 TO
Over 125 TO	Over 30 TO	Over 150 TO
Over 130 TO	Over 30 TO	Over 150 TO
Over 135 TO	Over 30 TO	Over 150 TO
Over 140 TO	Over 30 TO	Over 150 TO
Over 145 TO	Over 30 TO	Over 150 TO
Over 150 TO	Over 30 TO	Over 150 TO

ITEM	NAME OF PART	NO. OF PART	Q'TY	MATERIAL	NOTE
DWG.	CHK	DATE	23.11.09	UNITS	MM
CHK	DATE	SCALE	1:1	SHEET/OF	A4 / 1/1
APP.	DATE	NAME	MX2EDGRK-5.08-XXP		

CI XI MAIXU ELECTRONICS CO.,LTD.
慈溪市迈旭电子有限公司

DWGNO. 1