

注: 本型产品禁止传输、复制、编辑被控文件, 以及用其内容进行交流

REV	ECN NO.	CONTENT	CHK	DATE

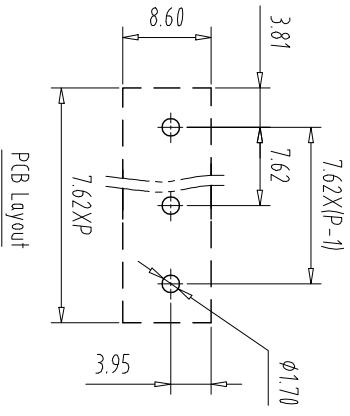
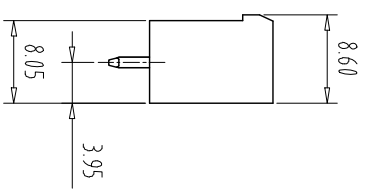
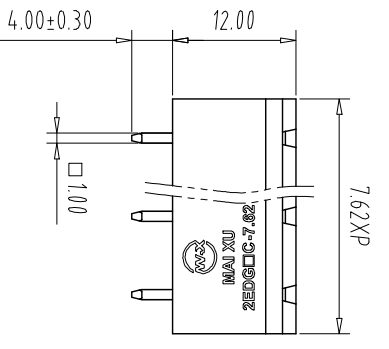
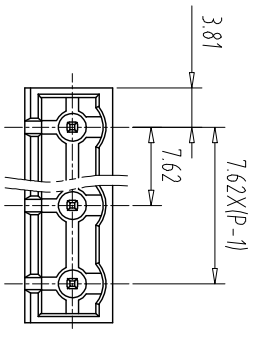

NOTES1:
UL Standard

1 Use group	B	C	D
Rated Current	15A	/	10A
Rated Voltage	300V	/	300V

2 withstanding voltage: AC1600V/1Min
IEC Standard

1 Pollution Degree	3	2	2
Overvoltage Category	III	II	II
Rate Impulse Voltage(KV)	/	4.0KV	/
Rate Voltage(V)	/	400V	/
Rate Current(A)	/	15A	/

NOTES2:

- 1.Housing: PA66 (UL94V-0)
- 2.Solder Pin: Brass (Sn Plated)

NOTES3:

- 1.Pitch: 7.62mm Poles: 02-24P
- 2.Operating temperature: -40℃~+105℃
- 3.RoHS Compliance

How to order

MX2EDGVC - 7.62 - XXP - XXXX - X - X

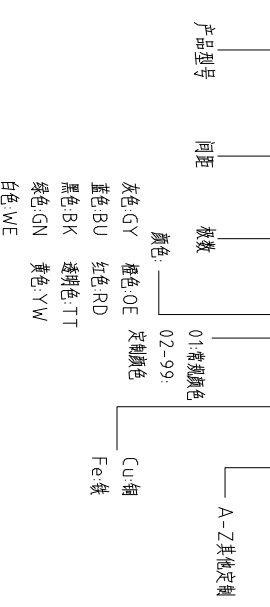

Pitch Range In mm		Nominal Dimension Range In mm	
Over 6	Over 10	Over 30	Over 60
TO 6	TO 10	TO 30	TO 60
Over 10	Over 24	Over 60	Over 100
TO 10	TO 24	TO 60	TO 100
Over 150	Over 150	Over 150	Over 150
TO 150	TO 150	TO 150	TO 150

NAME	Q'TY	MATERIAL	NOTE
MX2EDGVC-7.62-XXP	1/1	MM	1/1

ITEM	NAME OF PART	NO OF PART	Q'TY	MATERIAL	NOTE
DWG	CHK	DATE	SCALE	SHEET/OF	1/1
APP	DATE		1:1	A4	

MAIXU 慈溪市迈旭电子有限公司
 CIXI MAIXU ELECTRONICS CO.,LTD.
 DWGNO.