

注: 本资料禁止传输、复制、编辑或修改, 以及用其内容进行复制

REV	ECN NO.	CONTENT	CHK	DATE

NOTES1:
UL Standard

1. Use group	B	C	D
Rated Current	8A	/	/
Rated Voltage	300V	/	/

IEC Standard

1. Pollution Degree	3	2	2
Overvoltage Category	III	III	II
Rate Impulse Voltage(KV)	2.5KV	2.5KV	2.5KV
Rate Voltage(V)	160V	160V	250V
Rate Current(A)	8A	8A	8A

NOTES2:

- 1.Housing: PA66 (UL94V-0)
- 2.Long Solder Pin: Brass (Sn Plated)
- 3.Short Solder Pin: Brass (Sn Plated)
- 4.Nut: Brass

NOTES3:

- 1.Pitch: 3.5mm Poles: 2x(02-24)P
- 2.Operating temperature: -40°C~+105°C
- 3.RoHS Compliance

How to order

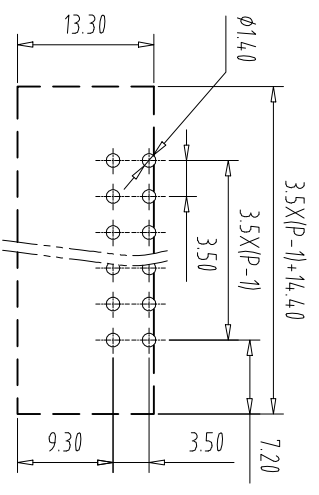
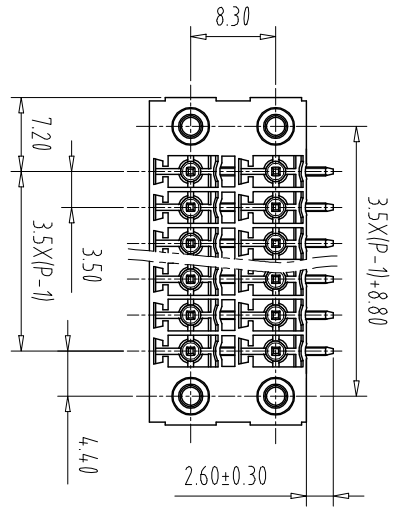
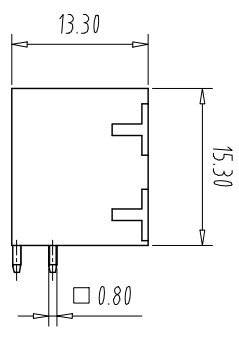
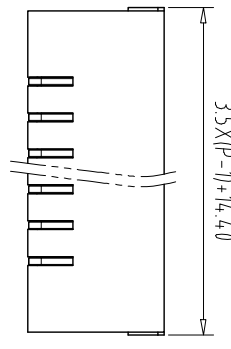
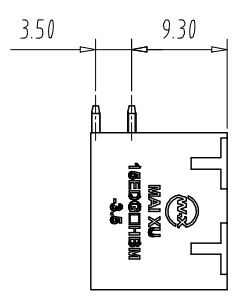
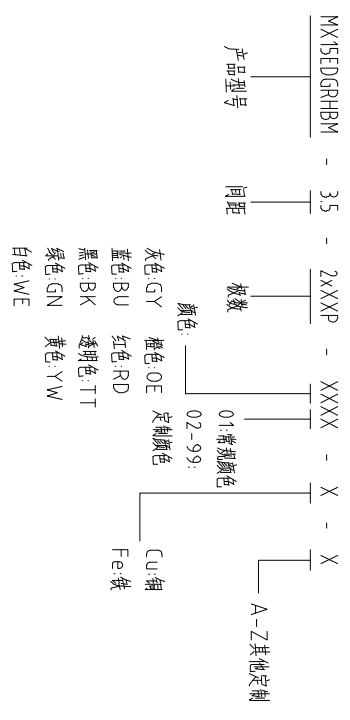

Pitch Range In mm		Nominal Dimension Range In mm		Pitch Range In mm		Nominal Dimension Range In mm	
Over 6	Over 10	Over 10	Over 30	Over 30	Over 60	Over 100	Over 150
TO 6	TO 10	TO 24	TO 30	TO 60	TO 100	TO 150	TO 150

±0.15	±0.20	±0.30	±0.30	±0.50	±0.70	±1.00	±1.30	±2°
-------	-------	-------	-------	-------	-------	-------	-------	-----

ITEM	NAME OF PART	NO. OF PART	Q'TY	MATERIAL	NOTE
DWG	CHK	DATE	SCALE	MM	SHEET/OF
APP	DATE	SCALE	1:1	A4	1/1
CIXI MAIXU ELECTRONICS CO.,LTD.			MX15EDGRHBM-35-2XXXXP		
MAIXU 慈溪市迈旭电子有限公司			DWGNO.		