

注: 本图仅供参考, 复制、翻印、修改、以及用其内容者均须依此

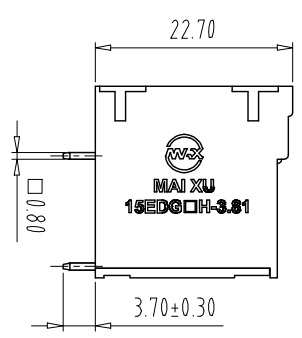
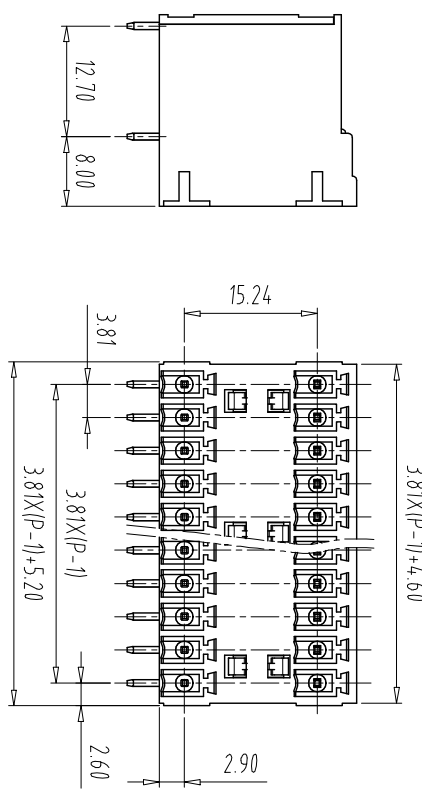
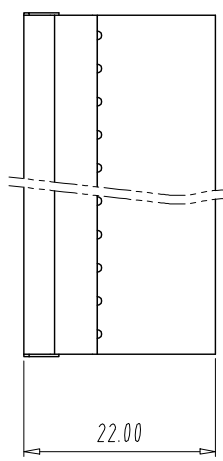

UL Standard

Use group	B	C	D
Rated Current	8A	/	8A
Rated Voltage	300V	/	300V

IEC Standard

Pollution Degree	3	2	2
Overvoltage Category	III	III	II
Rate Impulse Voltage(KV)	2.5KV	2.5KV	2.5KV
Rate Voltage(V)	160V	160V	250V
Rate Current(A)	7A	7A	7A

- NOTES2:
- 1.Housing: PA66 (UL94V-0)
 - 2.Cover: PA66 (UL94V-0)
 - 3.Long Solder Pin: Brass (Sn Plated)
 - 4.Short Solder Pin: Brass (Sn Plated)

- NOTES3:
- 1.Pitch: 3.81mm Poles: 2x(02-24)P
 - 2.Operating temperature: -40°C~+105°C
 - 3.RoHS Compliance

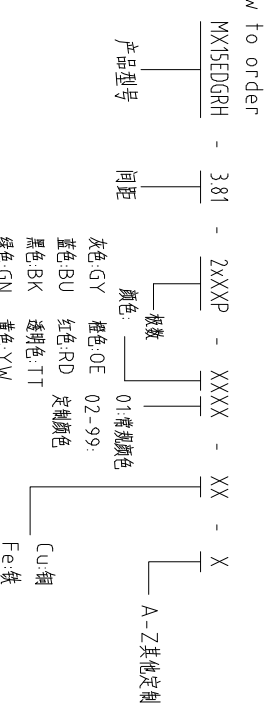

Pitch Range In mm

Over 6	Over 10	Over 10	Over 30	Over 60	Over 100	Over 100	Over 150
TO 6	TO 10	TO 24	TO 30	TO 60	TO 100	TO 150	
±0.15	±0.20	±0.30	±0.30	±0.50	±0.70	±1.00	±1.30

Nominal Dimension Range In mm

Over 30	Over 60	Over 100	Over 150
TO 30	TO 60	TO 100	TO 150
±0.30	±0.50	±0.70	±1.00

PCB Layout

0.1/10	±2°
--------	-----

ITEM	NAME OF PART	NO. OF PART	Q'TY	MATERIAL	NOTE
DWG	CHK	DATE	UNITS	MM	SHEET/OF
APP	DATE	SCALE	1:1	A4	1/1
NAME					
MX15EDGRH-3.81-2xXXP					

DATE: 23.08.11

SCALE: 1:1

NAME: MX15EDGRH-3.81-2xXXP

DATE: 23.08.11

SCALE: 1:1

NAME: MX15EDGRH-3.81-2xXXP

MAIXU 慈溪市迈旭电子有限公司