

注: 本图仅供参考, 复制、翻印、扫描、以及用其他设备复制

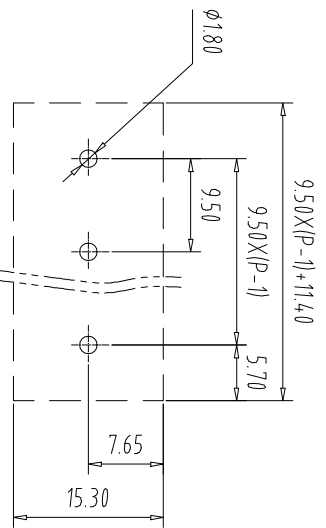
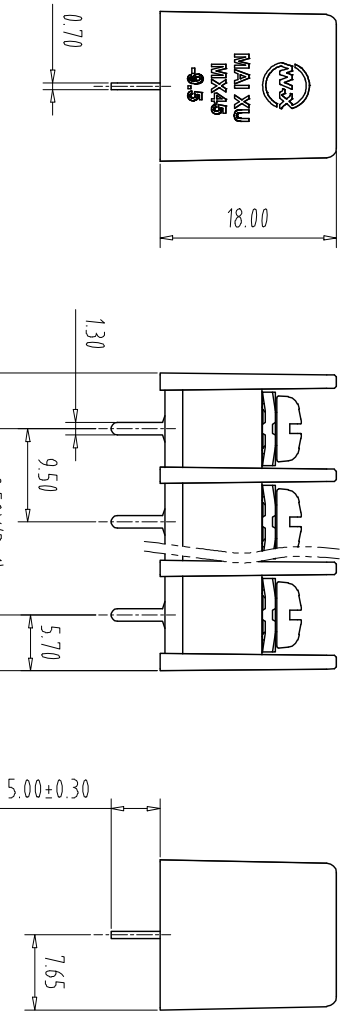
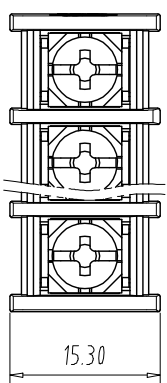

PCB Layout

Pitch Range In mm		Nominal Dimension Range In mm		Over		Pitch Range In mm		Nominal Dimension Range In mm		Over	
TO	6	TO	10	TO	30	TO	60	TO	100	TO	150
±0.15	±0.20	±0.30	±0.30	±0.30	±0.50	±0.70	±1.00	±1.00	±1.30	±2°	

REV	ECN NO.	CONTENT	CHK	DATE

NOTES 1:
UL Standard

1 Use group	B	C	D
Rated Current	20A	/	/
Rated Voltage	300V	/	/

- 2. Torque value: M4, 10.53Lb.in
- 3. Wire range: 22~12AWG

IEC Standard

1 Pollution Degree	3	2	2
Overvoltage Category	III	III	II
Rate Impulse Voltage(KV)	/	4	/
Rate Voltage(V)	/	400V	/
Rate Current(A)	/	24A	/

- 2. Torque value: M4, 1.2Nm
- 3. wire range: 0.5-4.0mm²

NOTES 2:

- 1. Housing: PA66(UL94V-0)
- 2. Solder Pin: Copper alloy(Sn Plated)
- 3. Screw: Steel(M4, Ni Plated)

NOTES 3:

- 1. Pitch: 9.50mm Poles: 02-24P
- 2. Operating temperature: -40°C~+105°C
- 3. RoHS Compliance

How to order

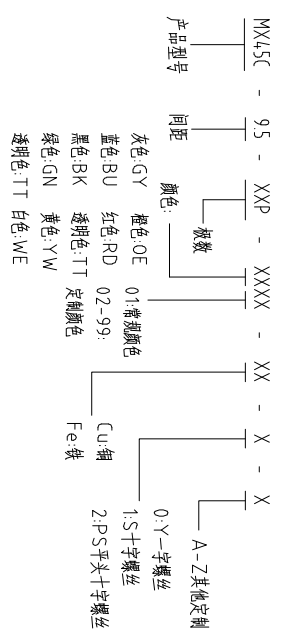

ITEM	NAME OF PART	NO. OF PART	Q'TY	MATERIAL	NOTE
DWG	CHK	DATE	DATE	UNITS	MM
APP	DATE	SCALE	SCALE	SHEET/OF	1/1
CIXI MAIXU ELECTRONICS CO.,LTD.			MX45C-9.5-XXP		
慈溪市迈旭电子有限公司			DWGNO.		