

注：本板为禁止运输、复制、翻印文件，以及利用其内容建设网站

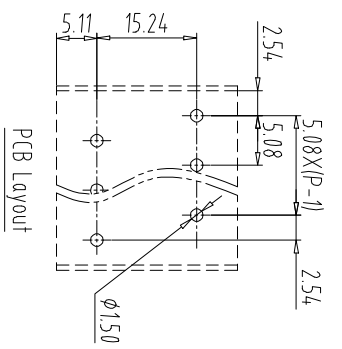
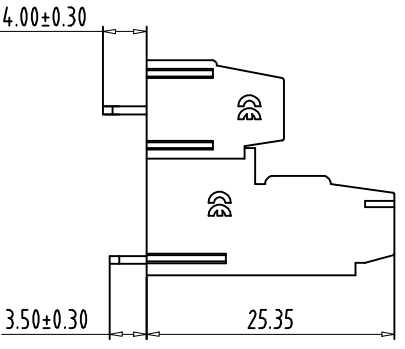
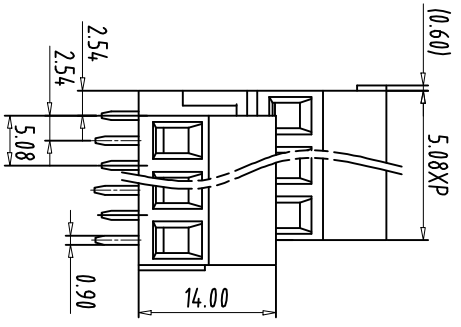
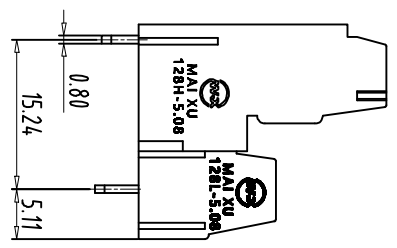
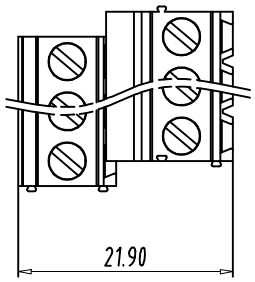

REV	ECN NO.	CONTENT	CHK	DATE

- NOTES1:
UL Standard
1.Rating voltage/current: 300V//10A
2.withstanding voltage: AC1600V//1min
3.Torque value: M2.5, 3.54LbIn
4.Wire range: 24~12AWG
IEC Standard

Pollution Degree	3	2	2
Overvoltage Category	III	III	II
Rate Impulse Voltage(KV)	4	4	4
Rate Voltage(V)	250V	400V	630V
Rate Current(A)	10A	10A	10A

1. Torque value: M2.5, 0.4Nm
3.wire range: 0.2-2.5mm²

NOTES2:

- Housing 1: PA66(UL94V-0)
- Housing 2: PA66(UL94V-0)
- Cage: Brass(Ni Plated)
- Solder Pin 1: Copper alloy(Sn Plated)
- Solder Pin 2: Copper alloy(Sn Plated)
- Screw: Steel(M2.5, Zn Plated)

NOTES3:

- Pitch: 5.08mm Poles: 2X(2-24)P
- Stripping length: 6-7mm
- Operating temperature: -40℃~+105℃
- RoHS Compliance

How to order

MX128HLA - 5.08 - XXP - XXXX - XX - X - X

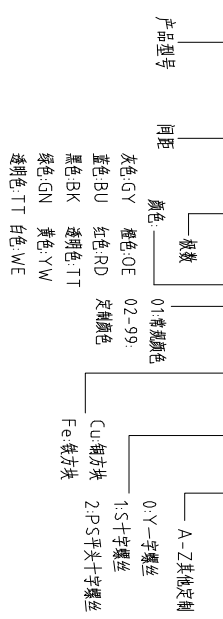

Pitch	Range	In mm	Nominal Dimension	Range		
mm	Over 6	Over 10	Over 30	Over 60	Over 100	Over 150
TO	6	10	24	30	60	100
	±0.15	±0.20	±0.30	±0.30	±0.50	±0.70
					±1.00	±1.30
						±2°

ITEM	NAME OF PART	NO. OF PART	Q'TY	MATERIAL	NOTE
DWG	CHK	DATE	SCALE	SHEET/OF	1/1
APP	DATE	DATE	SCALE	A4	
			NAME		
			MX128HLA-5.08-XXP		
			DWGNO.		

MAIXU 慈溪市迈旭电子有限公司

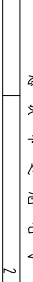

CIXI MAIXU ELECTRONICS CO.,LTD