

注：本板为禁止运输、复制、编辑文件，以及用其内容进行交流

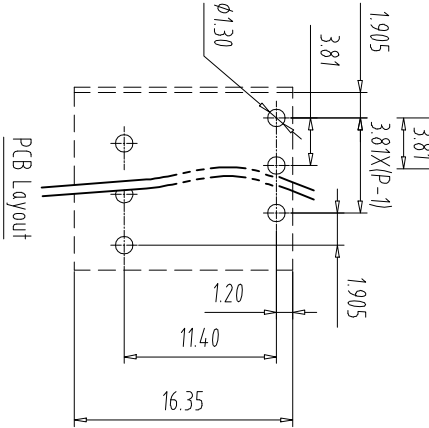
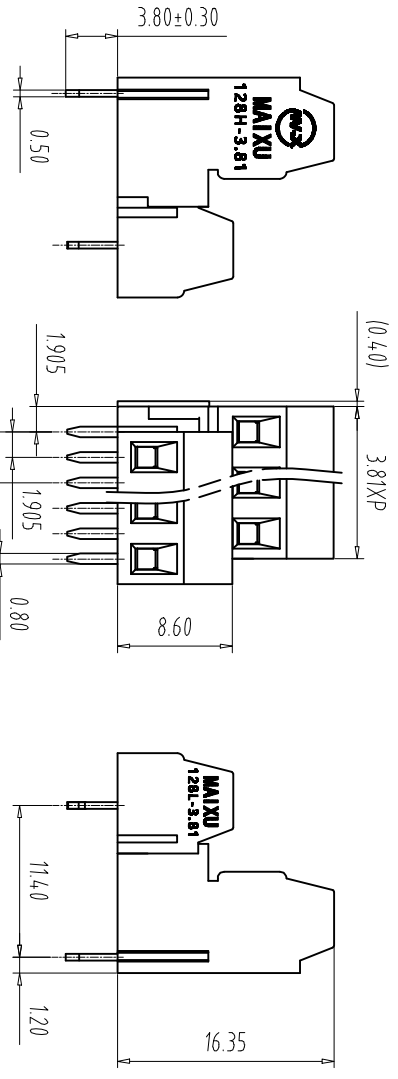
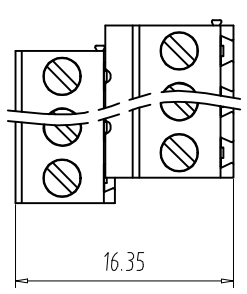

REV	ECN NO.	CONTENT	CHK	DATE

NOTES 1:
 UL Standard
 1.Rating voltage/current: 150V/12A
 2.withstanding voltage: AC1600V/1Min
 3.Torque value: M2, 1.77Lb.in
 4.Wire range: 30~14AWG
 IEC Standard

1. Pollution Degree	3	2	2
Overvoltage Category	III	III	II
Rate Impulse Voltage(KV)	2.5	2.5	2.5
Rate Voltage(V)	160V	200V	400V
Rate Current(A)	10A	10A	10A

NOTES 2:
 1.Housing: PA66(UL94V-0)
 2.Solder Pin 1: Copper alloy(Sn Plated)
 3.Solder Pin 2: Copper alloy(Sn Plated)
 4.Cage: Brass(Ni Plated)
 5.Screw: Steel(M2,Zn Plated)

NOTES 3:
 1.Pitch: 3.81mm Poles: 2X(02-24)P
 2.Stripping length: 5-6mm
 3.Operating temperature: -40~+105℃
 4.RoHS Compliance

How to order
 MX128HLA - 381 - XXP - XXXX - XX - X - X
 产品型号 间距 颜色 板数 01常规颜色
 灰色:GY 橙色:OE 02-99:
 蓝色:BU 红色:RD 定制颜色
 黑色:BK 透明色:TT
 绿色:GN 黄色:YW
 透明色:TT 白色:WE

Cu:铜方块
 1:S十字螺丝
 0-Y一字螺丝
 A-Z其他定制
 Fe:铁方块
 2:P平头十字螺丝

Pitch	Range	In	Nominal Dimension	Range
mm	Over	In mm	Over	Over
	6	10	30	60
	TO	TO	TO	TO
	10	24	60	100
	10	30	100	150
	±0.15	±0.20	±0.30	±0.50
			±0.70	±1.00
				±1.30
				±2°

ITEM	NAME OF PART	NO. OF PART	Q'TY	MATERIAL	NOTE
DWG	CHK	DATE	UNITS	SHEET/OF	1/1
APP	DATE	SCALE	SCALE	A4	1/1
CIXI MAIXU ELECTRONICS CO.,LTD			NAME		
MAIXU 慈溪市迈旭电子有限公司			MX128HLA-3.81-XXP		
DWGNO.					